

cegard/Smart CGSM-E

Door Protection Quick Start Guide



CEDES AG is certified according to ISO 9001:2015

Thank you for purchasing the CEDES cegard/Smart elevator door protection system. This “Quick Start” guide provides basic system concept information. This document does not replace the installation and operating instructions for the components included in this kit.

Consult the documents listed below for additional requirements, other warnings, and device specifications.

- 117 960 CE/UKCA Declaration of conformity
- 117 845 cegard/Smart controller Manual
- 117 940 CabSafe 3D Manual
- 118 748 cegard/Smart light curtain Manual
- 118 290 EComgard Brief Installation Manual

These documents are available online for download at: www.cedes.com.

IMPORTANT READ BEFORE INSTALLATION!

- Refer to electrical and grounding safety information in the controller installation section of this document.
- This door protection system must only be installed and commissioned by qualified elevator installation personnel.
- Before beginning installation of this door protection system, you must be sure that the elevator has been properly placed “Out of Service” to ensure that the elevator and related components will not be allowed to move during the installation. You must follow all applicable safety protocols, rules and regulations that apply.
- Upon completion of the installation and commissioning of this door protection system, qualified elevator installation personnel must ensure that the installation complies with all applicable local, regional and national regulatory requirements, and that the operation of the elevator control system, including this light curtain, perform in accordance with the application and regulatory requirements.

System overview

This cegard/Smart system is designed for use as part of an elevator door protection system.

The cegard/Smart light curtain forms an invisible field of criss-cross beams that detect the presence of persons or objects between the doors. By itself, this light curtain can fulfill requirements defined in EN81-20 and ASME A17.1 / CSA B44 (2016 version and earlier).

Adding the CabSafe 3D sensor to the system allows for the detecting the presence of approaching objects and functions as required by ASME A17.1 and CSA B44 (2019 and later versions).

When an object is detected, the output from the cegard/Smart controller changes state to indicate that the doors should be reopened.

Figure 1 shows a cegard/Smart system with one or two light curtains (no approaching object detection capability).

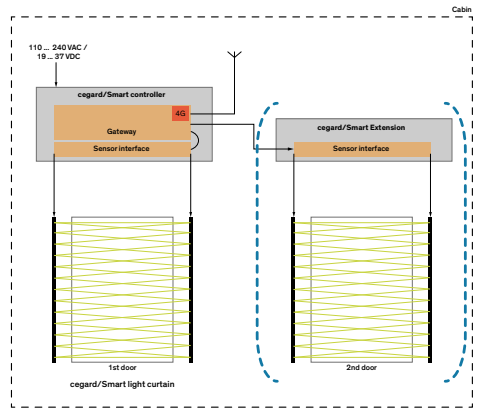

Figure 1: cegard/Smart 2D system - 1 door (in the blue bracket - 2 doors)

The non-hatched area (left side of the above figure) represents a **cegard/Smart EComgard One system**. The hatched area on the right includes an extension module and second light curtain. This configuration, along with the non-hatched area is a **cegard/Smart EComgard Two system**.

Figure 2 shows a cegard/Smart 3D One or Two system that includes one or two light curtains as well as one or two CabSafe 3D sensors.

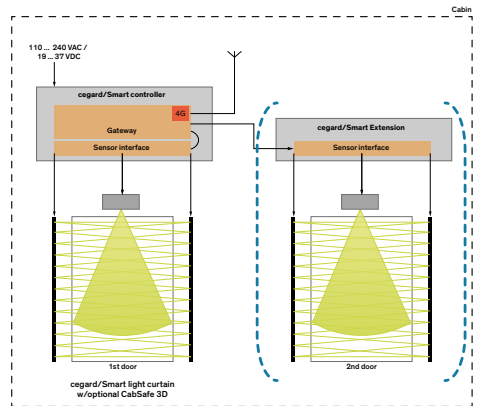

Figure 2: cegard/Smart 3D system - 1 door (in the blue bracket - 2 doors)

The non-hatched area (left side of the above figure) represents a **cegard/Smart EComgard 3D One system**. The hatched area on the right includes an extension module second light curtain, and second CabSafe 3D sensor. This configuration, along with the non-hatched area represents a **cegard/Smart EComgard 3D Two system**.

cegard/Smart extension module

The cegard/Smart Light controller extension module is used with elevators that have two entrances and is included with the **cegard/Smart EComgard Two** and **cegard/Smart EComgard 3D Two** systems.

The cegard/Smart controller connects to the extension module between cegard/Smart controller plug J5 and plug J14 on the extension module. A 5 m (16.4 ft) RJ45 connection cable is included with the extension module.

An optional 8 m (26.2 ft) is available. If an 8 m cable is needed in your application, order CEDES PN: 117 767.

Step by Step

The cegard/Smart system can be implemented into your application using the following process:

1. Locate and mount the controller on top of the elevator cabin. Ensure that the arrow on the cegard/Smart housing points to the landing door(s). Gain access to the terminals for the connection points by removing the controller cover.
2. When using an extension module,
 - a. Locate and mount the extension module on top of the cegard/Smart housing.
 - b. Remove the cover of the extension module to gain access to the terminals for the connection points.
 - c. Route the provided 5 m RJ45 to RJ45 cable between the extension module and the controller.
 - d. Connect the cable to J5 on the controller and J14 on the extension module.
3. For the EComgard cellular gateway, refer to the brief manual included with the device.
 - a. Mount the EComgard in accordance with the brief manual.
 - b. Connect the two-wire DSL conductors at the EComgard switch in the cegard/Smart controller through the traveling cable to DSL1 or DSL2 on the EComgard controller in the machine room.
4. Mount the cegard/Smart light curtain(s) to the elevator cab door(s) / strike jamb.
 - a. Connect the cables to the pigtailed on the transmitter (white) and receiver (blue).
 - b. Route cables back to the controller or extension module, avoiding high voltage signals / devices, and plug into the corresponding receptacle.
5. When using the CabSafe 3D sensor for approaching object detection:
 - a. Choose if the sensor will be mounted into the transom (flush mount) or by using the back of transom bracket.
 - b. Follow the mounting instructions included with the CabSafe 3D sensor for mounting. Refer to the CabSafe 33D sensor section of this document for additional details.
 - c. Route cable(s) back to the controller or extension module, avoiding high voltage signals / devices, and plug into the corresponding receptacle.
 - d. If using a magnetic switch/actuator for the render inoperative functionality, refer to the CabSafe 3D Operating Instructions for additional information.

6. Configure the controller and extension module DIP switches to meet your application requirements. Refer to the DIP switch configuration section of this document for additional detail.
7. Connect the relay output(s) from the controller or extension module to the corresponding door operator control input(s) for reopening devices.
 - a. Use COM-NO contacts if the operator wants signal when there is no object detected.
 - b. Use COM-NC contacts if the operator needs signal when an object is detected or no power.
8. Apply power to the EComgard controller – **Note:** It may take a few minutes for the controller to complete its boot-up sequence (i.e., before LEDs illuminate).
9. Apply power to the cegard/Smart controller. Refer to cegard/Smart controller section on page 6 for additional requirements.
10. Complete onboarding process – see separate section later in this document.

Verify system operates correctly

After your cegard/Smart devices are installed, verify that the system operates correctly using the following procedure:

1. Ensure that the controller, the 2D light curtain and the CabSafe 3D sensor are installed in accordance with the Installation and Operation Manual instructions and that the controller DIP switches are set correctly.
2. If not already the case, switch on power to the system. The POWER LED on the controller will change from OFF to green ON.
3. Wait 5 s after power cycle to ensure that components have completed the initial start-up sequence.
4. With the elevator door(s) in their fully open position and all detection fields clear of objects, ensure that the LEDs on the controller indicate the following:

a. Power LED	Green ON
	Power present
b. LED “3D”	Amber OFF or flashing
	No object detected or rendered inoperative
c. LED “Tx/Rx”	Amber OFF
	No object detected
d. LED “OUT”	Amber OFF or ON
	Depends on DIP switch 10 setting

If any LED state(s) is different than shown above, verify that the installation of:

- a. the 2D light curtain is correct if the LED “LC” is ON and should not be, and
- b. the 3D sensor is correct if the LED “3D” is ON and should not be.

Correct any installation details and cycle power. Return to Step 3.

5. Verify that 2D light curtain and controller function correctly and as expected:
 - a. As the elevator doors are closing, infringe the 2D light curtain detection field using your hand. When this infringement occurs, the elevator door(s) must reverse to their fully open position.
 - b. As the elevator doors are closing, infringe the 2D light curtain detection field using your foot at sill level. When this infringement occurs, the elevator door(s) must reverse to their fully open position.

6. Verify that CabSafe 3D sensor and controller function correctly and as expected:
 - a. Ensure that the 3D sensor is active (LED on sensor is solid blue / not flashing blue). If the 3D sensor is inoperative (blue flashing), infringe the 2D light curtain to change the 3D sensor back to active.
 - b. Starting from 1.2 m (4.0 ft) from the landing side of the entrance, walk toward the entrance at a speed between 0.3 m/s and 1.0 m/s (1 ft/s and 3.3 ft/s) perpendicular to the center of the opening.
 - c. The 3D sensor must indicate an approaching object has been detected (LED turns green) prior to reaching 225 mm (9 in) from the landing side of the landing door and the elevator door(s) must reverse to their fully open position.

As long as the above procedure is successful, functionality of the system has been third-party certified to fulfill section 2.13.5 of ASME A17.1 / CSA B44. No further testing is required. The third-party certificate is available online at www.cedes.com.

For ASME A17.1 / CSA B44 Force Testing of Door(s):

Since the Approaching Object Detection Means can be rendered inoperative in accordance with Section 2.13.5.2 of ASME A17.1 / CSA B44, testing of the force of the door(s) can be accomplished by measuring the force at the landing door(s) after the approaching object detection means has been rendered inoperative. There are no special procedures required to accomplish this testing.

cegard/Smart light curtain 2D

The cegard/Smart light curtain consists of a transmitter and receiver that are mounted on the elevator cab doors in a center-opening application or on the elevator cab door and the strike jamb in a side-opening application. Application requirements include:

- The maximum door speed must be less than 0.5 m/s (1.64 ft/s).
- The maximum door width must be less than 3 m (9.6 ft).
- The lowest beam must be less than 25 mm (1 in) above the sill.
- The optical axis must be within $\pm 10^\circ$ between the transmitter and receiver.

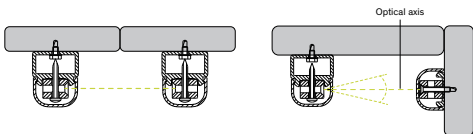

Once the cegard/Smart light curtain components are mounted, connect the cables from the transmitter and receiver to the corresponding connectors on the cegard/Smart controller.

Secure the cables in place, allowing enough slack so that they can bend freely, without becoming snagged on moving parts. Use cable guide wires on door(s) to prevent excessive cable sway.

CabSafe 3D sensor

CabSafe 3D sensors included with **cegard/Smart EComgard 3D One** and **cegard/Smart EComgard 3D Two kits**. It is used for the detection of persons or objects approaching the elevator cab entrance and operates in accordance with ASME A17.1 and CSA B44 (2019 and later versions) requirements.

The CabSafe 3D sensor is a Time-of-Flight (TOF) transom-mounted device that projects a detection field in front of the elevator cab entrance. For OEM applications where the transom already has a cut-out for the sensor, the mounting is straightforward using an optional backplate included with the sensor and two (2) security screws (spanner type).



When mounted, the cable must exit right from the CabSafe 3D sensor as you look into the cab (regardless of left-open, right-open or center-open application).

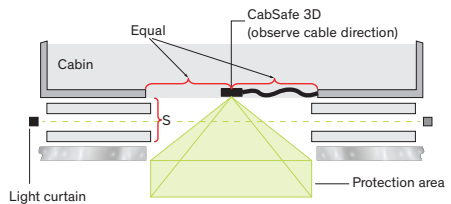

Figure 3: CabSafe 3D sensor mounted in center of opening

For center mounting applications, the sensor should be centered in the opening as shown above. For side-mounting applications, the sensor must:

- Be positioned no more than 240 mm (9.5 in) from the strike jamb (slam post).
- Be less than 300 mm (12 in) from the landing side of the landing door (Distance "S").

Route the cable from the CabSafe 3D sensor to the CabSafe controller. Connect the cable to the CabSafe 3D sensor and then secure the sensor in the transom. An optional stainless-steel back of transom bracket is also available for modernization applications.

cegard/Smart controller

The cegard/Smart controller has multiple printed circuit boards (PCBs). The Gateway PCB (lower) includes 100 ... 240 VAC power connections. Physical earth (PE) is connected to the grounding stud on the bottom plate of the housing.

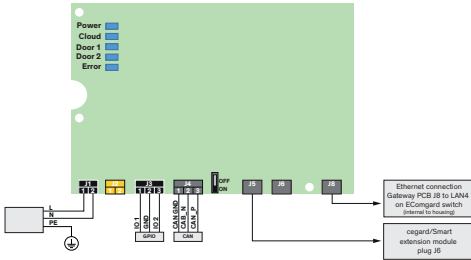

Grounding

- Mechanical installation:** Fasten the device to the top of the elevator cabin by appropriate means. Don't encroach on the safe space.
- Using a three-wire cable, connect the AC voltage and neutral wires to the corresponding terminals on connector J1. Connect the Protective Earth (PE / ground) wire to the grounding post using and appropriately sized ring terminal. The Protective Earth (ground) wire should be at the same as the elevator's earth potential. 
- Grounding / Earthing:** Always use the grounding post to create a dedicated connection to Protective Earth (PE) potential. Fastening the controller to the top of the car is not sufficient earthing / grounding. When using a 3-wire cable, leave the PE wire longer than the voltage and neutral wires.
 - Crimp a 4 mm (#8) ring terminal on the PE wire. Do not wrap the wire around the post. Check your local electrical code for the minimal allowed PE wire size. The PE wire size must always be equal or greater than the power supply wires (on connector J1).
 - Remove any visible contamination e.g., oily residue or rust from the base plate around the grounding stud.
 - The stacking order is base plate - nut - (optional serrated washer) - flat washer - ring terminal - flat washer - serrated washer - nut. Use a 7 mm wrench to tighten the nuts.

Side view

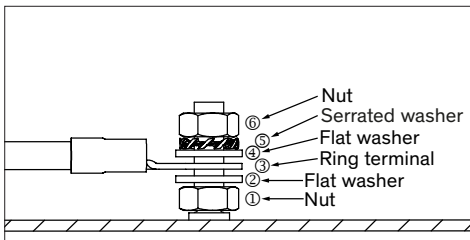

- ① Nut
- ② Flat washer
- ③ Ring terminal
- ④ Flat washer
- ⑤ Serrated washer
- ⑥ Nut

Top view

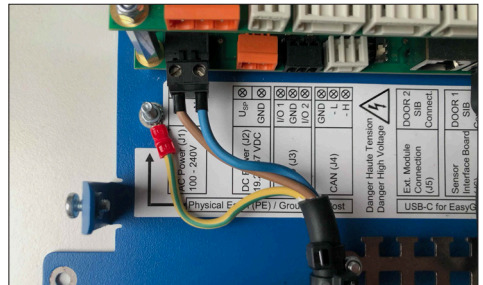

- After having done all electrical connections, close the top cover and properly tighten all four screws on the sides.

When an extension module is used, it is connected to the RJ-45 receptacle marked J5.

The Sensor Interface Board (upper PCB) is where the light curtain, CabSafe 3D sensor and external signals get connected. This board provides sensor information via LED indicators and is configured using DIP switches. A 3-pole connector provides a relay (dry contact) output for connection to door control. The same Sensor Interface PCB is used in the extension module.

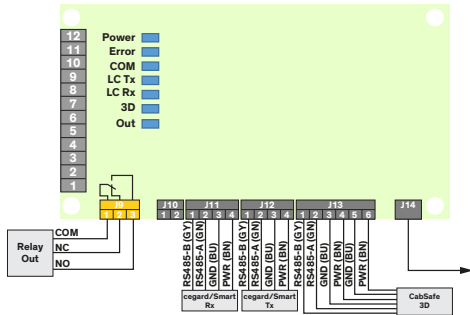

Connect the system devices as follows:

- When used, an external signal (i.e., magnetic switch) is connected to J10. See CabSafe 3D Manual for additional information.
- Light curtain transmitter connects to J11
- Light curtain receiver connects to J12
- CabSafe 3D sensor connects to J13
- For J14 shown (black arrow):
 - o For extension module, connect to controller J5
 - o For controller, it is pre-connected to J6.

DIP switch configuration

DIP SW 1 & 2 – CabSafe 3D location

The CabSafe 3D location is the position of the sensor as you look into the elevator cab from the landing side. For side-opening applications, the CabSafe 3D sensor must be mounted on the same side as the slam post / strike jamb.

Mounting position	DIP 1	DIP 2
No function	0	0
Left (Figure 5)	1	0
Right (Figure 4)	0	1
Center (Figure 3)	1	1

Distance “D” as shown below is 240 ± 10 mm (9.45 ± 0.4 in).

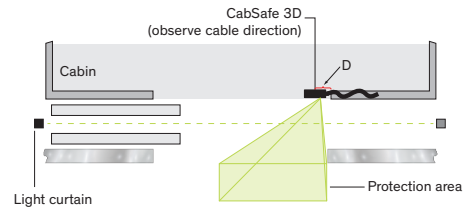

Figure 4: CabSafe 3D sensor mounted on right side

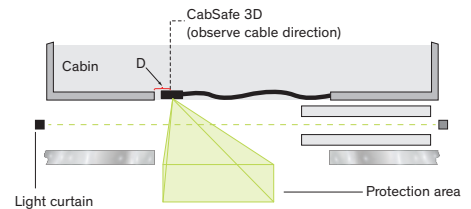

Figure 5: CabSafe 3D sensor mounted on left side

DIP SW 3 & 4 – Door closed detection

Normally, the light curtain is able to detect when the doors have reached a point when the CabSafe 3D sensor can be rendered inoperative. When the light curtain does not move with the door(s), an external signal is used to render the CabSafe 3D inoperative. The external signal should transition less than 450 mm (18 in) from full close. For additional information, see CabSafe 3D Manual.

Function	DIP 3	DIP 4
Not allowed	0	0
Via light curtain	1	0
Via external signal	0	1
Not allowed	1	1

DIP SW 5 – 8: Sensor mounting height

Select based on the mounting height of the CabSafe 3D.

Door height range	DIP 5	DIP 6	DIP 7	DIP 8
No function	0	0	0	0
6.66 ft to 7.5 ft (2.03 m to 2.3 m)	1	0	0	0
>7.5 ft to 8.5 ft (>2.3 m to 2.6 m)	0	1	0	0
>8.5 ft to 9 ft (>2.6 m to 2.74 m)	0	0	1	0
>9 ft to 10 ft (>2.74 m to 3.05 m)	0	0	0	1

DIP SW 9: 2D/3D select

To fulfill ASME A17.1 / CSA B44 2019 and later versions, both the cegard/Smart light curtain (2D) and CabSafe 3D must be active. If DIP 9 is configured as 2D Only, the CabSafe 3D sensor must be disconnected from the CabSafe controller.

Bypass 3D sensor	DIP 9
2D and 3D both active	0
2D Only (CabSafe 3D sensor must be disconnected)	1

DIP SW 10: Output logic selector

This configuration changes the polarity of the output.

Output logic selection	DIP 10
Standard (NO-COM)	0
Inverted (NC-COM)	1

Normally Open (NO-COM)



Normally Closed (NC-COM)



DIP SW 11: 3D frequency selector

This setting is used to prevent interference between CabSafe systems when elevators face one another.

Operation frequency selection	DIP 11
Standard - frequency range group A	0
Modified - frequency range group B	1

DIP SW 12: Standard vs. limited Region of Interest

This setting is used to reduce the field size in smaller openings with deep entrances.

Region setting	DIP 12
Standard - normal operation	0
Using smaller Region of Interest	1

DIP SW 12 should only be used when door opening widths are 1,100 mm (43.31 in) or less.

This function is possible when the CabSafe 3D sensor has SW Index 1.04 or greater.

On-Boarding process

Before you begin, please note that the system can only be on-boarded with a subscription and associated login credentials!

If you have not been issued login credentials, please contact your system administrator.

To begin the onboarding process, scan the QR Code using your smartphone or tablet. Then, follow each step.



When prompted, scan the 2D Code that is on the type label on the cegard/Smart controller.

Example type label on cegard/Smart controller

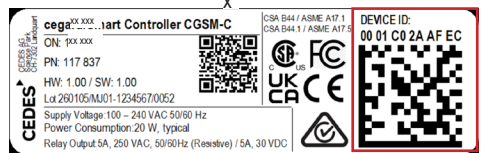

Troubleshooting cegard/Smart controller

LED status lower PCB in controller (all LEDs green)

Power	Tx	Rx	Gateway	Output	Actions to consider
0	0	0	0	0	<ul style="list-style-type: none"> ▶ Check electrical connections. ▶ Check supply voltage.
X	0	X	X	X	Transmitter not communicating: <ul style="list-style-type: none"> ▶ Check cable connection ▶ Check LED on transmitter
X	X	0	X	X	Receiver not communicating: <ul style="list-style-type: none"> ▶ Check cable connection ▶ Check LED on receiver
X	X	X	0	X	Gateway not connected: <ul style="list-style-type: none"> ▶ Check USB connection. ▶ Check power button on Gateway is illuminated blue; turn on if needed. ▶ Check power at 2P white connector is 12 VDC.

LED status indicated on upper PCB in controller

Power (Green)	Error (Red)	Out (Orange)	3D (Orange)	LC Tx / Rx (Orange)	Actions to consider
0	0	0	0	0	<ul style="list-style-type: none"> ▶ Check electrical connections from controller to power supply. ▶ Check supply voltage of the door controller.
1	0	0	0	0	▶ No error, normal operation, no object detected.
1	0	1	X	X	▶ No error, normal operation, no object detected.
1	0	1	0	1	▶ If cegard/Smart light curtain is not interrupted, follow troubleshooting instructions in cegard/Smart LC manual.
1	0	0	F	0	▶ 3D rendered inoperative - 3D timeout has occurred. - Doors < 450 mm from full close.
1	F	1	X	X	▶ Check error code according to the table next page (Pulse error definition).

1 = ON 0 = OFF F = Flashing X = Don't care

Error flash codes

1 Flash / 1 Pause	<ul style="list-style-type: none"> ▶ Internal CabSafe 3D sensor error or manipulation. ▶ Check if CabSafe 3D sensor is damaged or has been covered. If not, then please replace CabSafe 3D sensor.
3 Flash / 1 Pause	▶ Invalid cegard/Smart controller / extension module configuration.
4 Flash / 1 Pause	▶ Internal error, replace controller / extension module.
6 Flash / 1 Pause	▶ Communication issue between controller / extension module and CabSafe 3D sensor.
9 Flash / 1 Pause	▶ General system error (e.g. IC temperature, voltage, etc.).

cegard/Smart light curtain LEDs

Tx LED 1 Power	Rx LED 1 Power	Rx LED 2 Status	Actions to consider
0	0	0	<ul style="list-style-type: none"> ▶ Check electrical connections. ▶ Check supply voltage. ▶ Restart the system.
0	1	1	<ul style="list-style-type: none"> ▶ Check transmitter (Tx) connection – M8×6 white. ▶ Check power to the transmitter (Tx).
1	0	0	<ul style="list-style-type: none"> ▶ Check receiver (Rx) connection – M8×6 blue. ▶ Check power to the receiver (Rx).
1	1	0	<ul style="list-style-type: none"> ▶ No object detected. ▶ Normal operation (no action required)
1	1	1	Object detected, normal operation. If there is no object present, <ul style="list-style-type: none"> ▶ Check alignment. ▶ Clean front windows ▶ Check connections. ▶ Check relay connection / power supply
1	1	B	<ul style="list-style-type: none"> ▶ Ensure detection area is clear. ▶ Clean the front window. ▶ Ensure cables and edges are located away from sources of electromagnetic interference (EMI). ▶ Ensure no other infrared light sources or ambient light sources are nearby or facing the receiver, e.g., a security camera ▶ Ensure that the transmitter and receiver are correctly aligned and remain aligned during door closure (e.g., that vibrations do not cause edges to become misaligned). ▶ Measure U_{SP} voltage. ▶ Restart the system

1 = ON 0 = OFF B = Blinking / sporadic blinking

CabSafe 3D sensor LEDs

LED color	Description
OFF	No Power. <ul style="list-style-type: none"> ▶ Check electrical connections. ▶ Check supply voltage.
Green ON	▶ Object detected.
Blue ON	▶ No object detected.
Blue flashing	Normal operation, CabSafe 3D sensor is rendered inoperative <ul style="list-style-type: none"> ▶ 3D timeout has occurred (5 s). ▶ Doors < 450 mm
Red flashing	Error Detected <ul style="list-style-type: none"> • 1 Flash/Pause: Internal sensor error • 3 Flash/Pause: Configuration error • 4 Flash/Pause: Replace sensor • 6 Flash/Pause: Communication error ▶ Ensure that the optic of the CabSafe 3D sensor is oriented toward the lobby. <ul style="list-style-type: none"> ▶ Make sure the field of view is clear of interruption. ▶ Clean the optical windows with a soft cloth. ▶ Make sure that the cable is located away from sources of electromagnetic interference. ▶ Ensure supply voltage is in specification ▶ Restart the system.

Delivery package

North American Kits

cegard/Smart kits consist of two boxes that make up a system. The smaller box includes the controller, the communications interface, and depending on the kit ordered, an extension module and/or CabSafe 3D sensor(s). The larger box includes the light curtain and mounting accessories as shown below.



European Kits

cegard/Smart kits consist of two boxes that make up a system. The smaller box includes the controller, the communications interface, and depending on the kit ordered, an extension module and/or CabSafe 3D sensor(s). The larger box includes the light curtain and mounting accessories as shown below.



The more common North American cegard/Smart kits are:

P/No	Model designation	Description
Light curtain only for front-only or front and rear doors:		
117 921	CGS-SY-B1-12D000-2	cegard/Smart One CGSM-B1 7' NA
117 922	CGS-SY-B1-22D000-2	cegard/Smart Two CGSM-B1 7' NA
Light curtain & TOF 3D for front-only or front and rear doors:		
117 923	CGS-SY-B1-13DBSTBT-2	cegard/Smart 3D One CGSM-B1 7' BOT NA
117 924	CGS-SY-B1-23DBSTBT-2	cegard/Smart 3D Two CGSM-B1 7' BOT NA
Light curtain & emergency communication for front-only or front and rear doors:		
117 925	CGS-SY-E1-12D000-2	cegard/Smart EComgard One 7' NA
117 926	CGS-SY-E1-22D000-2	cegard/Smart EComgard Two 7' NA
Light curtain, TOF 3D & emergency communication for front-only or front and rear doors:		
117 927	CGS-SY-E1-13DBSTBT-2	cegard/Smart EComgard 3D One 7' BOT NA
117 936	CGS-SY-E1-23DBSTBT-2	cegard/Smart EComgard 3D Two 7' BOT NA

The more common European cegard/Smart kits are:

P/No	Model designation	Description
Light curtain only for front-only or front and rear doors:		
117 928	CGS-SY-B2-12D000	cegard/Smart One CGSM-B2 EU
117 929	CGS-SY-B2-22D000	cegard/Smart Two CGSM-B2 EU
Light curtain & TOF 3D for front-only or front and rear doors:		
117 930	CGS-SY-B2-13DBSTFL	cegard/Smart 3D One CGSM-B2 EU
117 931	CGS-SY-B2-23DBSTFL	cegard/Smart 3D Two CGSM-B2 EU
Light curtain & emergency communication for front-only or front and rear doors:		
117 932	CGS-SY-E2-12D000	cegard/Smart EComgard One EU
117 933	CGS-SY-E2-22D000	cegard/Smart EComgard Two EU
Light curtain, TOF 3D & emergency communication for front-only or front and rear doors:		
117 934	CGS-SY-E2-13DBSTFL	cegard/Smart EComgard 3D One EU
117 935	CGS-SY-E2-23DBSTFL	cegard/Smart EComgard 3D Two EU

Dimensions

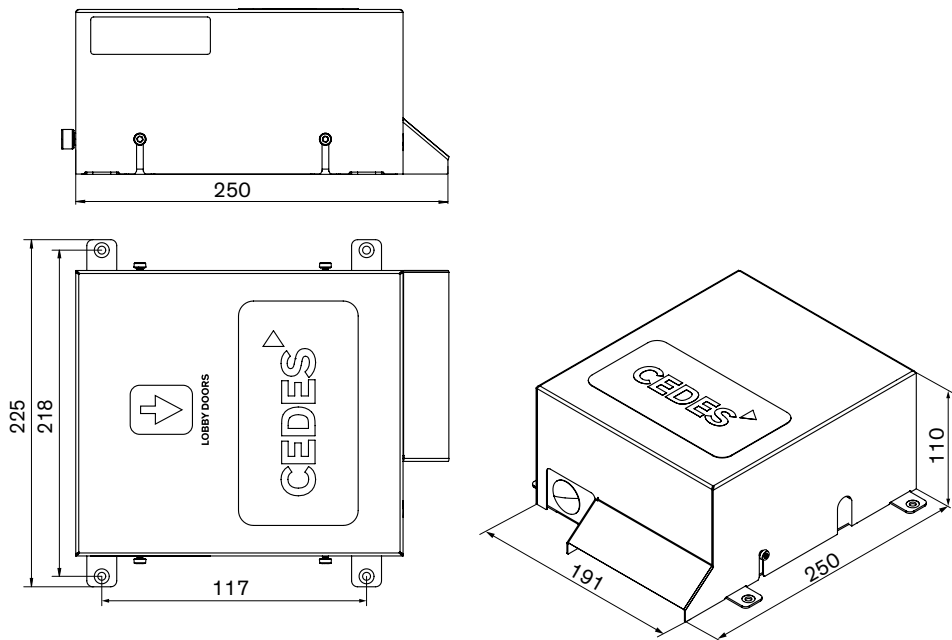

Please note:

When an expansion module is used, the mounting holes are located underneath the CEDES label.

